



# UAC ROOFING SHINGLES

**Versatile!**

**Distinctive!**

**Combine elegance  
with 'old world'  
charm.**

For new homes or commercial projects, re-roofing of older homes or restoration of historic buildings, UAC Roofing Shingles provide a distinctive alternative to other roofing materials.

UAC Roofing Shingles are manufactured from single faced sheet machined to produce four shingles per sheet. UAC Roofing Shingles are available in natural grey.

UAC Roofing Shingles can be set as low as  $17\frac{1}{2}^{\circ}$  with sarking, or  $22\frac{1}{2}^{\circ}$  without sarking. UAC Roofing Shingles combine a neat, crisp appearance with style, elegance and 'old world' charm. They are virtually maintenance free, and may be used for walling and roofing new homes, commercial and civil projects, reroofing older homes, or restoration of historic buildings.

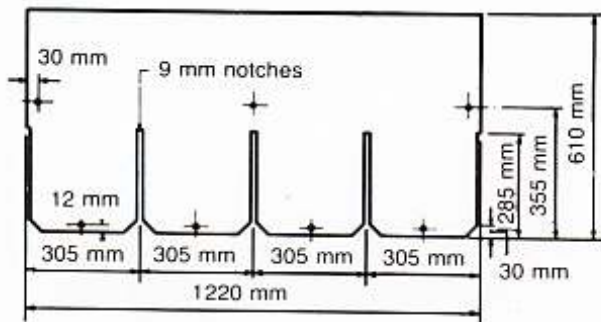

### NOMINAL DIMENSIONS (mm)

	Shingles	Starter Sheets
Width	1220	1220
Depth	610	355
Thickness	4.5	4.5
Coverage	325 per 100 m <sup>2</sup>	

Mass: approx. 4.0 kg/m<sup>2</sup> of finished roofing (based on average moisture content.)

### STORAGE

UAC's Roofing Shingles must be kept dry at all times prior to erection, preferably under cover such as shed or roofing overhang. If covered with plastic sheeting or tarpaulins, ensure there is adequate provision for 'breathing'. Stack on level seating.

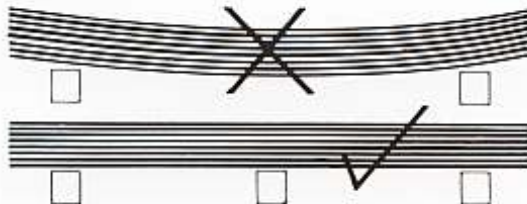

### ACCESSORIES AND FIXINGS

**Starter Sheet:** 1220 x 355 mm x 4.5 mm

Note: Starter sheets can be made up on site from full shingles, the off cuts providing ridge shingle 'leaves'.

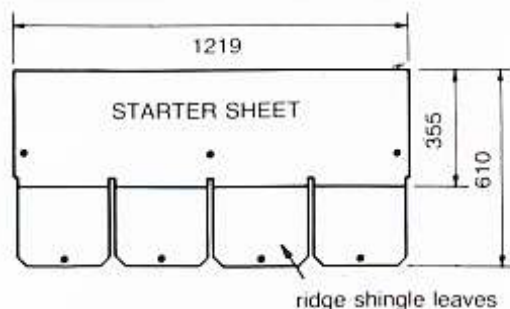

### Crampons

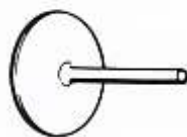

### Clouts

2.8 mm hot dipped galvanised clouts. 40 mm long for use with softwood battens. 30 mm long for use with hardwood battens.



### Ridge and Hip Fixing Screws

40 x 10g zinc or cadmium plated round head wood screws with neoprene/metal bonded washer.



### Flashing

Bitumen coated aluminium flashing.

### DESIGN CRITERIA

#### ROOF PITCH

The minimum recommended roof pitch is 17°. The following table outlines recommended design criteria for various roof pitches and degrees of exposure.

Roof Pitch	Specification
17° to 22 ½°	Foil Sarking recommended
Exposed conditions	Where roof pitch exceeds 22 ½°, Foil Sarking recommended
22 ½° plus	Under normal conditions no sarking required

**Design Wind Velocity** Shingles are not recommended for use on structures having a design velocity exceeding 33 m/sec.

### FIXING INSTRUCTIONS

#### ROOF FORMING

All primary roof framing should be constructed in accordance with good building practice and comply with local building regulations.

The following table outlines minimum batten sizes for a range of rafter spacings.

Rafter Spacing (mm)	Minimum Batten Sizes (mm)
450	22 x 45
600	35 x 45
900	35 x 45
1200	45 x 45

Tops of all ridge and hip boards should be set level with or below the tops of the battens. Fascias should be nailed to the ends of rafters, with the top edge projecting above the rafters by the batten thickness plus 2.0 mm.

#### WARRANTY

The recommendations in this brochure are formulated along the lines of good building practice. However, this brochure is not intended to be an exhaustive statement of all relevant data.

As the success of building projects depends on many factors outside UAC's control (e.g. quality of workmanship, particular design detail requirements etc.), UAC accepts no responsibility or liability for or in connection with the quality of the projects or their suitability when completed.

For a warranty period of one year from date of delivery of UAC's products ('UAC Products') to the purchaser ('Warranty Period'), UAC warrants that the UAC Products are free from defects which are solely due to materials or manufacturing faults. The foregoing warranty shall not apply to the extent that:

- the defect, loss or damage is caused by any act, default or misuse of the UAC Products (or part thereof) by the purchaser or any third party or by failure to follow any instruction or specifications of UAC or by modification of the UAC Products or installation, application and/or combination of the UAC Products with any other product not approved by UAC; or
- UAC is not notified in writing within the Warranty Period of any relevant defect in the UAC Products or part thereof.

Subject to such provisos, UAC will at its sole option and subject to the investigations, verifications and inspection of such defect by a UAC representative, either (a) replace such defective UAC Product or part thereof, or (b) refund the price paid for the defective UAC Product or part thereof. The liability of UAC shall include only Products with antecedent defects. The liability cannot be extended to include Products without defects which might have been delivered at the same time as the defective Products. The foregoing shall be the sole and exclusive remedy in the event of any breach of the said warranty.

To the greatest extent permitted by any applicable law, the warranties referred to the above shall be sole and exclusive and in lieu of all implied or statutory warranties (including without limitation, the implied warranties imposed by the Malaysian Sale of Goods Act 1957 and all other warranties implied by law as to merchantability, satisfactory quality or fitness for a particular purpose, or otherwise arising from course of dealing or usage of trade) or any other express or implied warranties or representations.

To the greatest extent permitted by any applicable law, in no event shall UAC be liable to the purchaser or any other person or entity for any loss or damage including without limitation special, indirect, incidental, punitive, exemplary or consequential damages, loss of profits, loss of business or loss of use, whether based upon contract, tort, negligence or otherwise arising out of the manufacture, sale or delivery of the UAC Products, even if UAC has been advised of the possibility of such damage or loss.



## Fixing Procedure

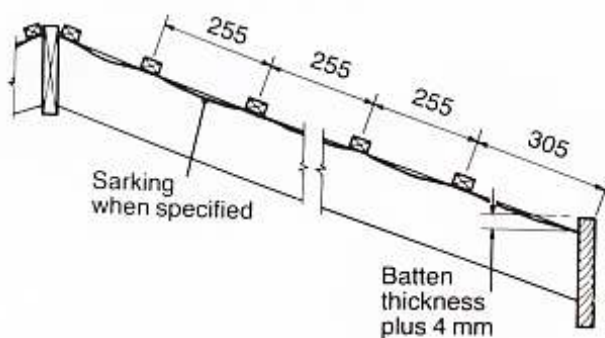

### 1. FIX BATTENS

Nail battens to each rafter in straight and parallel runs. (see diagram for spacing).

When sarking is used, it should be run in continuous lengths **across** the rafters & lapped between courses **before** fixing the shingle battens.



CERTIFIED TO MS ISO 9001 : 2000  
Registration No. AR 0387

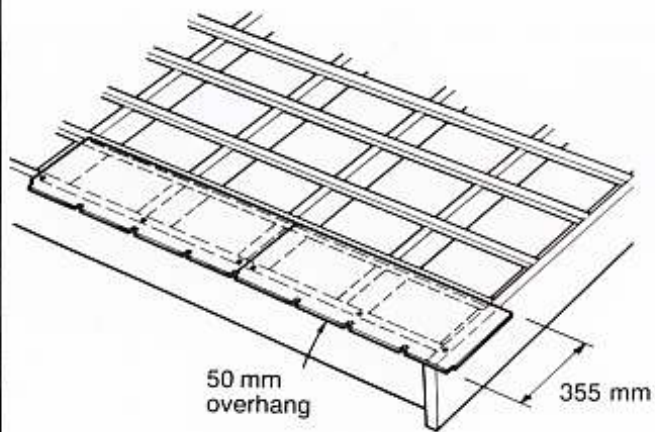

## 2. FIX STARTER SHEETS

Cut starter sheets from whole shingles. Position each starter sheet with the top edge located on or just below the centreline of the first batten. Fix to the top of the fascia with 30 x 2.5 mm hot dip galvanised clouts. Butt starter sheets closely together.

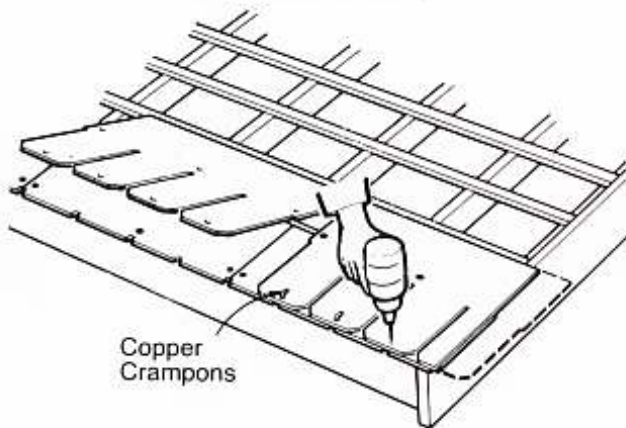

## 3. WORK UP THE ROOF

### First Course

Start by cutting 150 mm from the first 'leaf' of the first shingle (to allow joints between shingles to be staggered in successive courses).

Align the bottom and side edge of the first shingle with the starter sheet and fix into position. Close butt and fix second and successive shingles until first course is completed.

Using predrilled holes as a guide drill through starter sheet and fix each leaf with copper crampons.

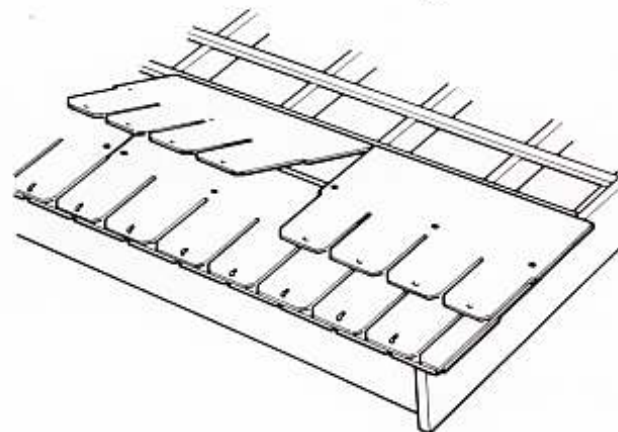

### Second Course

Start second course with a full shingle. Align crampton holes with the slots in the first course. Fix the second course in position.

### Third and Successive Courses

Start the third course as for the first course, ensuring that the crampton holes align with the slots of the second course.

Fix into position. Top edges of shingles should locate on or just below the centre line of the battens:

Continue fixing up to the ridge line, commencing alternate courses as stated. The top courses of shingles on opposite roof slopes should be cut so that the top edges touch over the centre line of the ridgeboard.

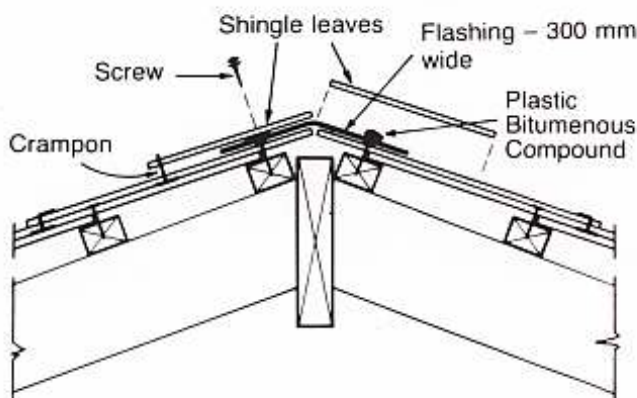

## 4. RIDGE

The last course of shingles for both slopes should be cut so that the top edges touch. Fix a continuous ridge flashing of 300 mm wide, then fix the shingle leaves (refer to notes on cutting of starter sheets) in position with copper crampions through the holes provided.

In addition fix each leaf with two 40 x 100 mm zinc or Cadmium plated round head wood screws and neoprene bonded washers.

Before screws are inserted, lift shingle leaf and apply Plastic Bitumenous Sealing Compound liberally around screw hole area.

Replace shingle leaf and screw down.

## 5. FIX COPPER CRAMPIONS

Crampon fixing should be carried out within 24 hours of laying shingles.

Start at the second shingle course, and work up the roof course by course. Insert copper crampions into the slots between the shingle leaves. Gently lift the edge of the shingle in the next course to allow the projecting shank of each crampton to be pushed through the holes provided. Firmly bend over each crampton shank at right angles and towards the ridgeline. This will ensure that each course of shingles is held in close contact with the previous course.

